

## Exercises of Activity Book

### 1 Match

1.

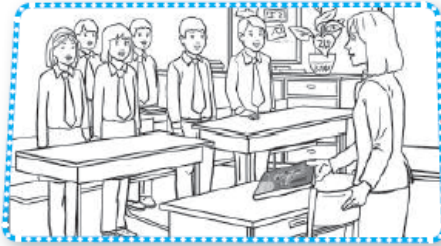

a.

Look at the board, please.

2.

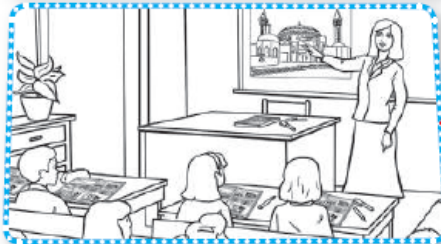

b.

Good morning, children.  
Good morning, Miss Rasmi.

3.



c.

Open your books, please.

Answers:

1. **b**    2. **a**    3. **c**

### 2 Look and copy

books    children    board

1. Good morning, **children**.
2. Open your **books**.
3. Look at the **board**, please.

### 3 Listen and say

Yes, it is    No, it isn't

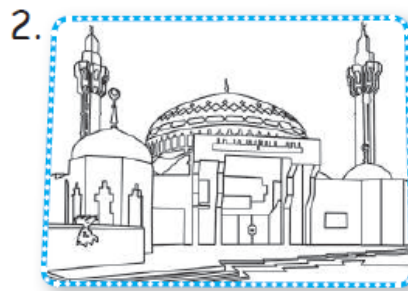
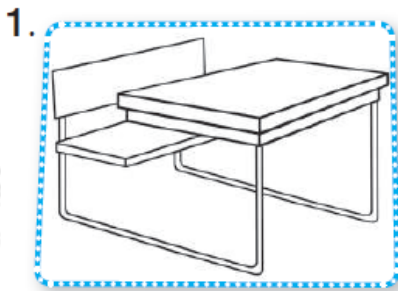

Tapescript

NARRATOR: 1

BOY 1: Is it a ruler?

NARRATOR: 2

BOY 2: Is it a mosque?

NARRATOR: 3

BOY 1: Is it a book?

Answers:

1. No, it isn't.
2. Yes, it is.
3. Yes, it is.

4 Match, trace and copy

mosque

Jordan

ruler

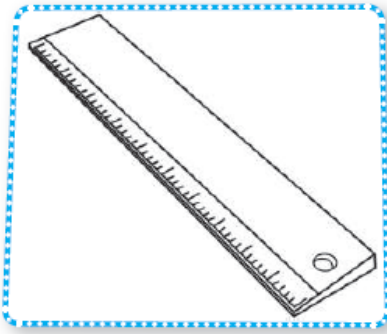

1. A ruler

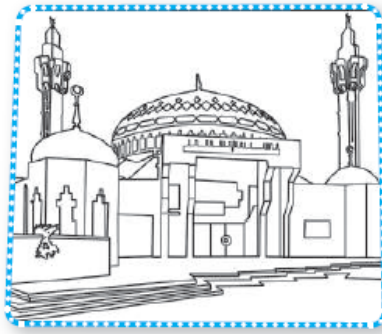

2. A mosque



3. Jordan

Answers:

1. A ruler.
2. A mosque.
3. Jordan.

### 5 Look, circle and say

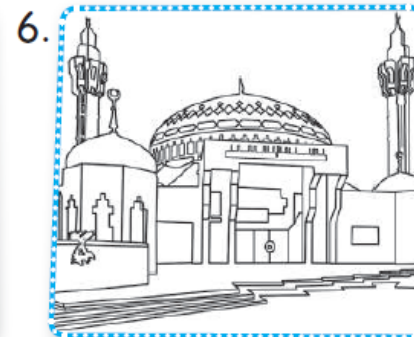
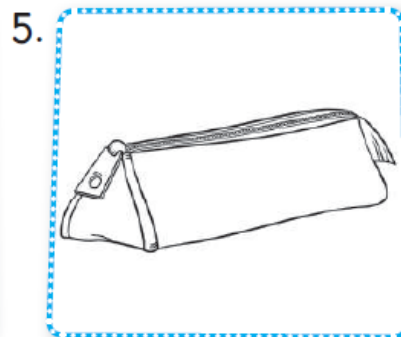
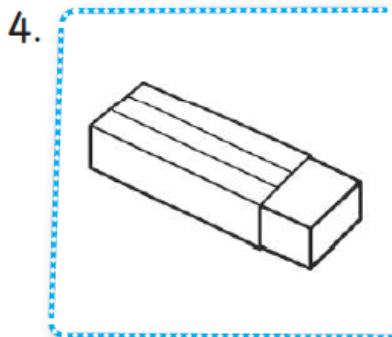
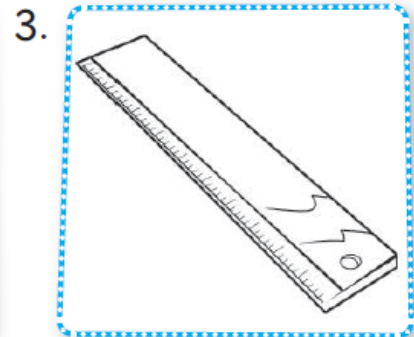
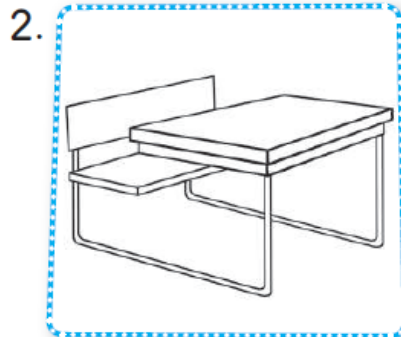

1. Is it a book?

Yes, it is / No, it isn't. (It's a desk).

2. Is it a pencil case?

Yes, it is / No, it isn't.

3. Is it a ruler?

Yes, it is / No, it isn't.

4. Is it a rubber?

Yes, it is / No, it isn't.

5. Is it a desk?

Yes, it is / No, it isn't. (It's a pencil case).

6. Is it a mosque?

Yes, it is / No, it isn't.